



Solutions for traction motors



Photo: ŠKODA ELECTRIC a.s.

The Power of Knowledge Engineering

Put yourself at the leading edge

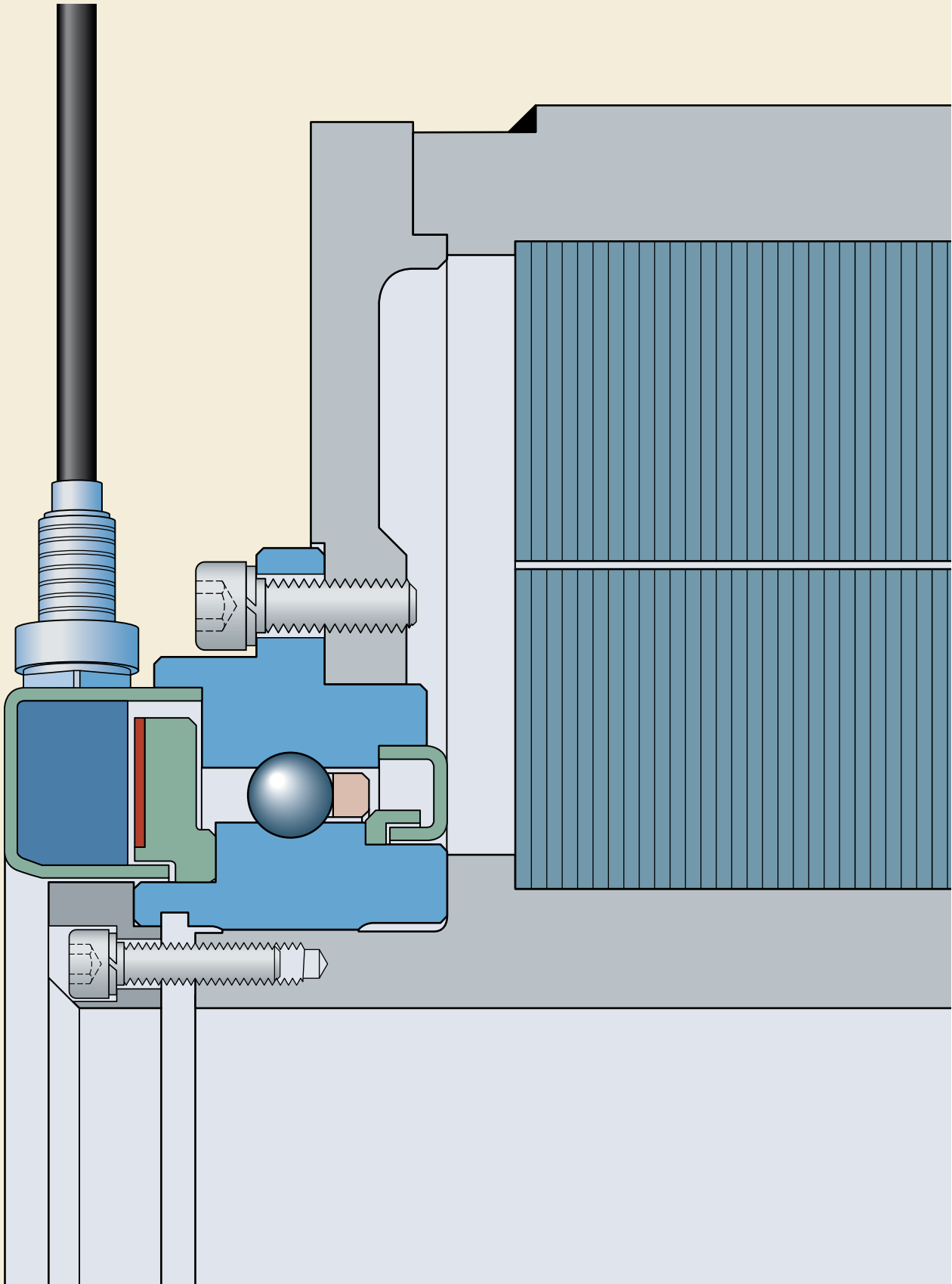

of traction motor design.

The operating conditions for traction motor bearings are very different from those normally encountered in electric motors in other industries. Traction motors must be robust, reliable, light and compact. They must also cope with difficult environments with a high level of contamination and humidity, as well as variations in speed, temperature, load, vibration and shocks.



Reliability is an essential requirement for modern traction motor bearings with long maintenance intervals. SKF has developed solutions to increase reliability by avoiding bearing damage caused by electric current passage.

Left side: Sensorised hybrid TMBU Traction Motor Bearing Unit equipped with ceramic balls, the incremental sensor detects absolute positioning for electric control devices, direction of rotation, speed for brake control systems and temperature to monitor reliability.

Meet your challenges with SKF

Backed by over 85 years of traction motor bearing expertise, SKF has been supporting the reliability and lower life cycle cost targets of all kinds of drive systems. The latest stage of the development are prelubricated bearing units with integrated seals and sensors. With expertise in bearings, services, seals, lubrication systems

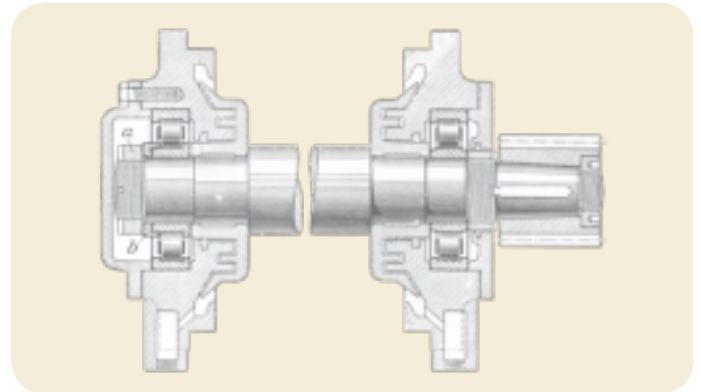

SKF traction motor bearing application from 1922 catalogue.

and mechatronics, SKF can offer unique highly reliable system solutions, such as:

- **locating bearing arrangements**
- **non-locating bearing arrangements**
- **sealed and prelubricated bearing units equipped with sensors**

Front page: Traction motor from ŠKODA ELECTRIC a.s. for low floor tramways.



Traction motor application principles

Nose suspended traction motor

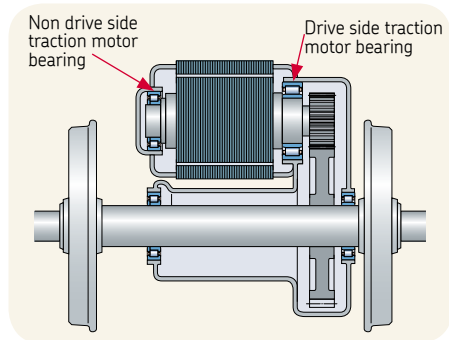

The nose suspended motor is the traditional traction design. Collectors and brushes are used especially for DC propulsion systems. The overhanging pinion on the drive side causes heavy radial forces on the adjacent bearing.

AC traction motor designs

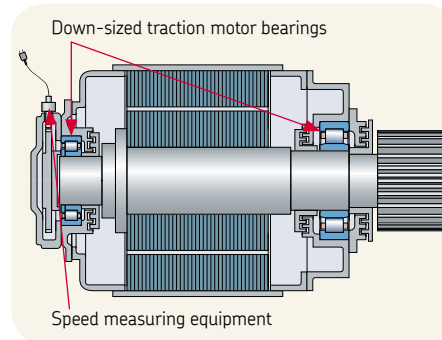

Due to the introduction of the 3-phase AC propulsion technique, speed limiting collectors and brushes could be dispensed with and maximum motor speed was increased to improve power. A speed sensor is flanged onto the opposite side to provide speed signals to the inverter system. In many cases the active iron length of the rotor and stator was lengthened to increase power by using the same traction motor boundary dimensions.

Integrated AC traction motor designs

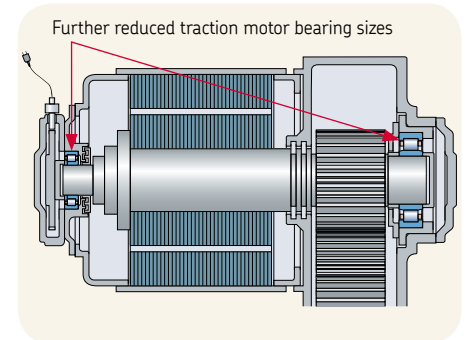

The integration of the traction motor and the drive system into a complete unit enables accommodating the pinion bearing in the gearbox. This design principle eliminates the effect of the overhanging pinion completely. The radial forces are reduced and smaller bearings can be selected to achieve higher traction motor speeds.

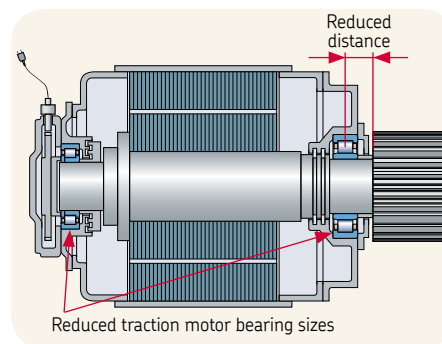
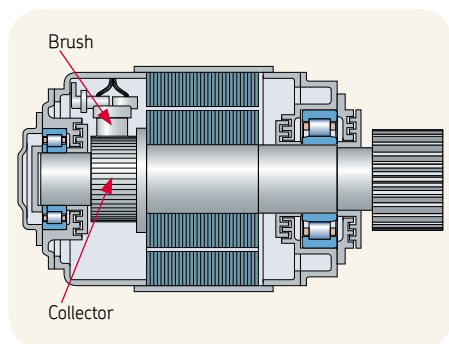

To manage higher traction motor speeds and to reduce the effect of the overhanging pinion, the adjacent bearing is lubricated with the oil from the gearbox. In some cases a non-locating N design cylindrical roller bearing is incorporated to reduce oil splashing and to lower operating temperatures.

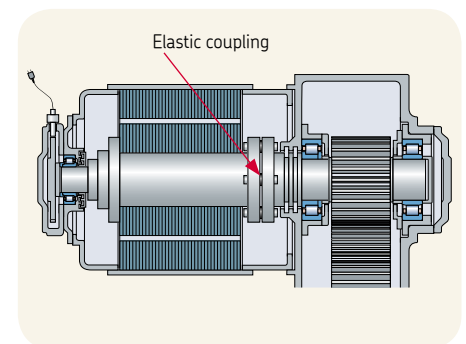

Another design principle are traction motors with one bearing arrangement only. In most cases a non-locating bearing is used. A special design enables having additional flanges on the inner ring of the cylindrical roller bearing for handling purposes only. The traction motor is flanged to the gearbox via an elastic coupling.



Traction motor with cardan shaft propulsion

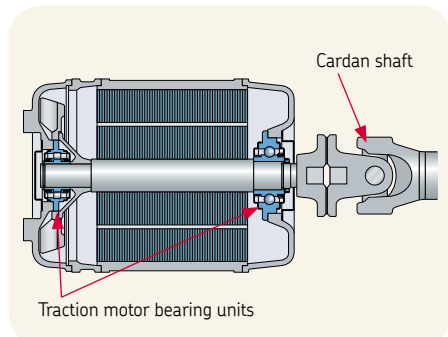

Especially for multiple units and mass transit vehicles, traction motors are used that are connected to the gearbox via a cardan shaft. In this case the radial loads are relatively low and determined by the rotor weight and some dynamic effects only.

The latest development in traction motor bearing design is the application of Traction Motor Bearing Units (TMBU) that are space saving, sealed and prelubricated bearing units. In some cases the active iron length of the rotor and stator is increased to gain more power by using the same boundary dimensions of the traction motor. TMBU's with integrated speed sensors help to save even more space and enable a much compacter traction motor design.

Traction motor for low-floor vehicles

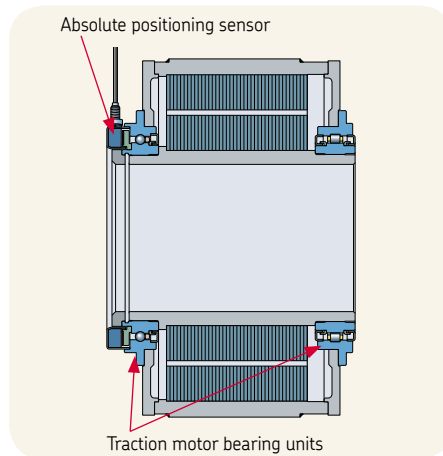

Today, most tramcars are designed as low-floor vehicles. This design principle helps passengers to enter the car easily. Special traction motor designs and drive system arrangements have to be applied because of space limitations.

The latest design is based on a hollow shaft arrangement and an integrated cardan shaft that directly drives the independent wheel. On both sides a hybrid TMBU is applied to gain space in axial direction. The integrated absolute positioning sensor with additional speed detection contributes further to the space saving approach. One TMBU is based on a cylindrical roller bearing design and the other one on a deep groove ball bearing design.

Integrated traction motor design for low floor vehicles

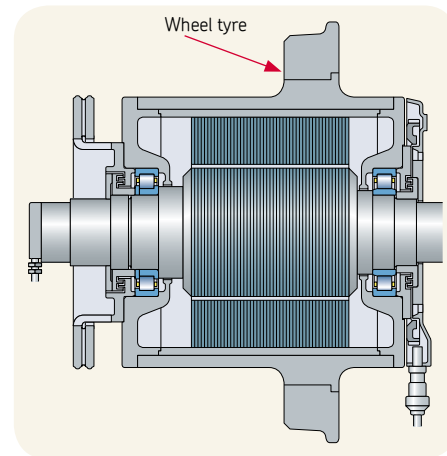

There are some highly specialized traction motor designs that are applied for modern drive systems. One of the most challenging designs is the integrated traction motor function within the wheel arrangement.

In this case the bearing inner rings are fitted onto the axle that is part of the bogie design. The wheel is part of the rotating outer part of the traction motor. The bearing arrangement has to accommodate all wheel forces and dynamic effects in radial and axial directions.



Solutions for locating and non-locating

Locating bearings provide axial location for traction motor shafts in both directions. In most cases deep groove ball bearings are used. For heavier radial loads, cylindrical roller bearings in the NJ design with an HJ angle ring or the NUP design are typically used.

Non-locating bearings must accommodate shaft movement in the axial direction, to avoid damaging induced heavy axial loads when, for example, thermal expansion of the shaft occurs.

Integrated drive system designs where the traction motor and the gearbox are mounted directly can be achieved with a traction motor arrangement based on only one bearing. This bearing can be a locating or non-locating bearing. The flanged gearbox accommodates the corresponding bearing function.

Traction motor bearings are usually equipped with a one or two-piece machined brass cage. For a number of specific applications, SKF supplies cylindrical roller bearings equipped with a polyetheretherketone (PEEK) cage.

Because of tighter shaft fits and operational temperature differences between the inner and outer rings, clearance classes like C4 and C5 are commonly used.

Deep groove ball bearings



Deep groove ball bearings are used as locating bearings in traction motors. Deep raceway grooves and the close conformity between the raceway grooves and the balls enable these bearings to accommodate axial loads in both directions, in addition to radial loads, even at high speed.



bearing arrangements

Cylindrical roller bearings



Non-locating cylindrical roller bearing designs

NU design

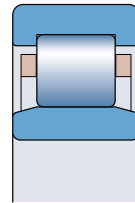

N design

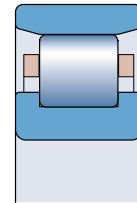

Locating cylindrical roller bearing designs

NJ design + HJ angle ring

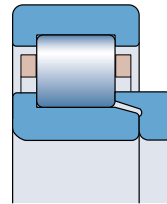

NUP design

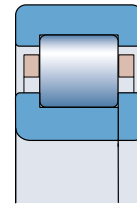

For non-locating bearing arrangements in traction motors cylindrical roller bearings are used, typically NU or N designs. The NU design is the most common; the outer ring has two integral flanges while the inner ring has no flanges. Axial displacement of the shaft relative to the housing can be accommodated in both directions.

Traction motors running with higher speeds and designed for oil lubrication are equipped in some cases with a N design bearing. These cylindrical roller bearings provide a lower operating temperature in comparison with NU design bearings.



Solutions for higher reliability

Due to the introduction of frequency converter controlled motors for propulsion systems in locomotives and multiple units, demands on traction motor bearings have significantly increased. High frequency stray electric currents are unavoidable in most current applications. The passage of electric current through rolling bearings can lead to damage in a short period of time.

SKF offers three basic design solutions for electrical insulation of traction motor bearings, depending on the application requirements. The electrical impedance is a vector function based on the Ohmic resistance, frequency and capacitance. The capacitance is a measure of the amount of electric charge stored for a given electric potential.

INSOCOAT VL0241 Electrically insulated outer ring



SKF INSOCOAT traction motor bearings are widely used for all kind of applications, especially for small and medium traction motors. The bearing design is based on standard bearing types, both cylindrical roller bearings and deep groove ball bearings. In most cases the outer ring is electrically insulated with an aluminium oxide layer.

- virtually eliminates premature bearing failures caused by stray electric currents

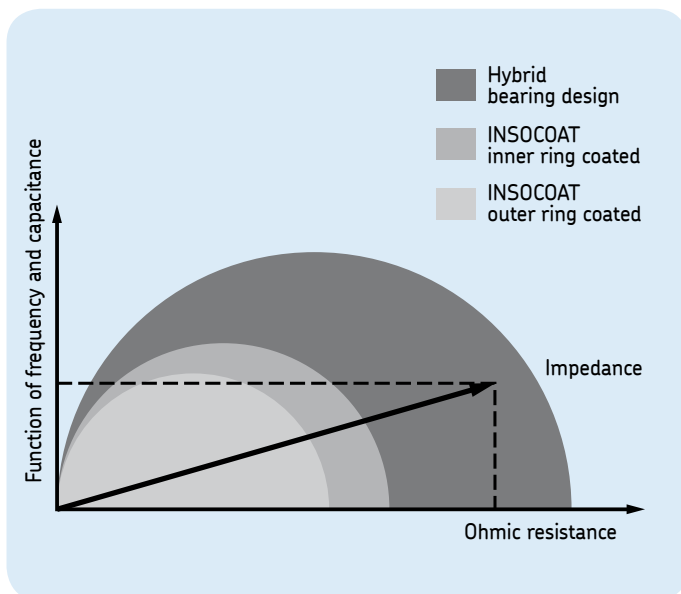



INSOCOAT VL2071 Electrically insulated inner ring



The inner ring insulation design principle offers an improved insulation performance, especially for larger traction motors. The aluminium oxide coating is applied on the inner ring outside surfaces: the bore, the chamfers and side faces.

- improved electrical insulation properties in comparison with the coated outer ring design VL0241
- lower electrical capacitance due to a smaller coated surface area
- higher electrical impedance

Hybrid bearings HC5



Hybrid bearings offer a further improvement of the electrical insulation properties, especially for modern high frequency inverter system applications. These bearings are equipped with rolling elements made of bearing grade silicon nitride.

- superior electrical insulation properties even at very high frequencies
- extended maintenance intervals, due to longer grease life compared with all-steel bearings
- energy saving capabilities because of lower friction and higher precision
- extended maintenance intervals because of lower operating temperature

Solutions with sealed and prelubricate

To achieve lower life-cycle cost, more and more sealed and greased bearing units are being used in railway applications. The TMBU Traction Motor Bearing Unit concept offers new opportunities for space savings, easier mounting, longer maintenance intervals and improved performance.

The TMBU is a sealed and prelubricated bearing unit designed for flange mounting on the housing. A special grease is selected to achieve extended grease life even at high operating temperatures. The bearing unit is equipped with non-contact labyrinth seals, frictionless and without wear.

To increase the reliability, electrical insulation is realized by using either an INSOCOAT coating or hybrid design with ceramic/silicon nitride rolling elements.

The TMBU concept offers space saving opportunities especially in axial direction. More traction motor power for given motor size can be achieved by using TMBU's.

Locating TMBU design



The TMBU design for locating bearing arrangements is based on a deep groove ball bearing design. This sealed and prelubricated bearing unit has an integrated flange on the outer ring to be bolted on to the traction motor shield.

Electrical insulation can be provided either by applying a hybrid design based on ceramic balls or with an electric insulating INSOCOAT layer on the bore of the inner ring.

- space saving, fewer parts
- unit concept enables very easy mounting
- sealed and greased for extended maintenance intervals



and bearing units equipped with sensors

Non-locating TMBU design



The TMBU Traction Motor Bearing Unit design for non-locating bearing arrangements is based on a cylindrical roller bearing design. This sealed and prelubricated bearing unit has an integrated flange on the outer ring to be bolted on to the traction motor shield.

Electrical insulation can be provided either by applying an electric insulating INSOCOAT coating on the bore of the inner ring, or by using a hybrid bearing equipped with silicon nitride rollers.

- space saving, fewer parts
- unit concept enables very easy mounting
- sealed and greased for extended maintenance intervals

TMBU sensor capabilities



The sensorised TMBU concept offers several detection and measurement opportunities:

- absolute positioning detection for traction motor control devices
- detection of direction of rotation
- speed measurement for brake control systems
- temperature measurement to monitor reliability

The incremental sensor unit is integrated into the sealing system of the outer ring of the bearing unit. This design is very space-saving, especially in axial direction compared with conventional sensor devices.

- space saving design, fewer parts
- high resolution and accuracy
- robust and long life design

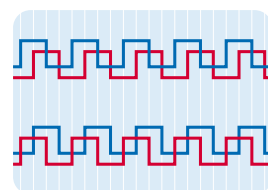

Output position signal clockwise

and counter-clockwise



References



Photo: SBB

Italian Pendolino ETR 460 tilting train generation, max. speed 250 km/h, traction motors made by Alstom, total power 6 000 kW, in operation since 1992.

SKF traction motor bearings:

Locating bearing:
INSOCOAT deep groove ball bearing
Non-locating bearing:
Cylindrical roller bearing



Photo: DB AG/Wolfgang Klee

German DB ICE 3 high speed train, max. speed 330 km/h, traction motors made by Siemens, power 16 x 500 kW, in operation since 1999.

SKF traction motor bearings:

Locating bearing:
INSOCOAT deep groove ball bearing
Non-locating bearing:
INSOCOAT cylindrical roller bearing



Photo: SBB

Swiss Railways SBB FLIRT RABe 521/523, max. speed 160 km/h, traction motors made by TSA Traktionssysteme, power 4 x 500 kW, in operation since 2004.

SKF traction motor bearing:

Locating bearing:
INSOCOAT TMBU Traction Motor Bearing Unit



Photo: Talgo

Spanish Talgo 350 high speed train, max. speed 350 km/h, traction motors made by Siemens, power 8 x 1 000 kW, in operation since 2005.

SKF traction motor bearing:

Single bearing arrangement:
INSOCOAT cylindrical roller bearing



Photo: KTX

Korean KTX high speed train, operational speed 300 km/h, traction motors made by Rotem, power 12 x 1 130 kW, in operation since 2004.

SKF traction motor bearings:

Locating bearing:
Cylindrical roller bearing
Non-locating bearing:
Four point contact ball bearing and cylindrical roller bearing



Photo: ÖBB

Austrian ÖBB Taurus electrical locomotive 1016/1116, max. speed 230 km/h, traction motors made by Siemens, power 4 x 1 600 kW, in operation since 2000.

SKF traction motor bearings:

Locating bearing:
INSOCOAT deep groove ball bearing
Non-locating bearing:
Cylindrical roller bearing



Photo: Siemens

Chinese Railways DJ4 electrical locomotive, max. speed 120 km/h, traction motors made by Siemens and Zhuzhou Electric Locomotives Works, power 8 x 1 200 kW, in operation since 2006.

SKF traction motor bearings:

Locating bearing:
INSOCOAT deep groove ball bearing
Non-locating bearing:
INSOCOAT cylindrical roller bearing



Indian WDG-2A diesel-electric freight locomotive, max. speed 100 km/h, traction motors made by BHEL, total power 3 100 HP / 2 300 kW, in operation since 1995.

SKF traction motor bearings:

Locating bearing:
Cylindrical roller bearing
Non-locating bearing:
Cylindrical roller bearing



Photo: DB AG/Günter Jazbec

German DB 152 electrical locomotive, max. speed 170 km/h, traction motors made by Siemens, power 4 x 1 600 kW, in operation since 2001.

SKF traction motor bearings:

Locating bearing:
INSOCOAT deep groove ball bearing
Non-locating bearing:
INSOCOAT cylindrical roller bearing



Photo: DB AG/Wolfgang Klee

German DB-Railion 189 electrical freight locomotive suitable for different European electric systems, max. speed 140 km/h, traction motors made by Siemens, power 4 x 1 600 kW, in operation since 2003.

SKF traction motor bearing:

Single bearing arrangement:
INSOCOAT cylindrical roller bearing



American diesel-electric locomotives are typically hauling very long freight trains, total power rating 3 000 HP / 2 200 kW up to 6 000 HP / 4 500 kW.

SKF traction motor bearings:

Locating bearing:
INSOCOAT deep groove ball bearing
Non-locating bearing:
INSOCOAT cylindrical roller bearing



Photo: SBB

Swiss SBB Re 460 electrical locomotive, max. speed 230 km/h, traction motors made by ABB, power 4 x 1 525 kW, in operation since 1992.

SKF traction motor bearings:

Locating bearing:
INSOCOAT deep groove ball bearing
Non-locating bearing:
INSOCOAT cylindrical roller bearing



References



Photo: Siemens

Slovenian Desiro EMR 312, max. speed 140 km/h, traction motors made by Siemens, power 4 x 412 kW, in operation since 2000.

SKF traction motor bearings:

Locating bearing:
INSOCOAT cylindrical roller bearing
Non-locating bearing:
INSOCOAT deep groove ball bearing



Indian 3-phase electric freight locomotive WAG-9, max. speed 100 km/h, traction motors made by ABB, power 6 000 HP / 4 474 kW, in operation since 1996.

SKF traction motor bearings:

Locating bearing:
Cylindrical roller bearing
Non-locating bearing:
Cylindrical roller bearing



Photo: Siemens

USA - Houston TX, MetroRail, Avanto light rail vehicle, max. speed 105 km/h, traction motors made by Siemens, in operation since 2001.

SKF traction motor bearing:

Non-locating bearing:
INSOCOAT cylindrical roller bearing



Photo: ŠKODA ELECTRIC a.s.

Czech Republic - Prague 15T low floor tramway, max. speed 60 km/h, traction motors made by ŠKODA ELECTRIC a.s., power 16 x 60 kW.

SKF traction motor bearings:

Locating bearing:
Hybrid TMBU Traction Motor Bearing Unit with integrated positioning and speed sensor (deep groove ball bearing)
Non-locating bearing:
Hybrid TMBU (cylindrical roller bearing)



Photo: Grazer Verkehrsbetriebe

Austria - Graz, Cityrunner, low floor tramway, max. speed 70 km/h, traction motors made by ŠKODA ELECTRIC a.s., power 8 x 50 kW, in operation since 2001.

SKF traction motor bearings:

Locating bearing:
INSOCOAT deep groove ball bearing
Non-locating bearing:
INSOCOAT cylindrical roller bearing



Photo: Gunter Mackinger

Austria - Salzburg, low floor trolley bus, max. speed 65 km/h, traction motor made by ŠKODA ELECTRIC a.s., power 1 x 172 kW, in operation since 2000.

SKF traction motor bearings:

Locating bearing:
INSOCOAT TMBU Traction Motor Bearing Unit (deep groove ball bearing)
Non-locating bearing:
INSOCOAT TMBU (cylindrical roller bearing)

Cylindrical roller bearings for traction motors

Standard product range for light loads¹

d 50 – 220 mm

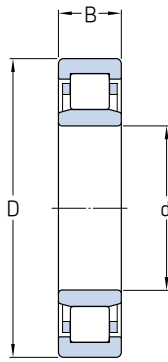

Principal dimensions ²			Preferred executions			Basic designation	
d	D	B	Standard bearing design	INSOCOAT outer ring coated VL0241	INSOCOAT inner ring coated VL2071		Hybrid design HC5
mm			–			–	
50	80	16	■	■		■	NU 1010 EC
55	90	18	■	■		■	NU 1011 EC
60	95	18	■	■		■	NU 1012
65	100	18	■	■		■	NU 1013 EC
70	100	20	■	■		■	NU 1014 EC
75	115	20	■	■		■	NU 1015
80	125	22	■	■		■	NU 1016
85	130	22	■	■		■	NU 1017
90	140	24	■	■		■	NU 1018
95	145	24	■	■		■	NU 1019
100	150	24	■	■		■	NU 1020
110	170	28	■	■		■	NU 1022
120	180	28	■		■	■	NU 1024
130	200	33	■		■	■	NU 1026
140	210	33	■		■	■	NU 1028
150	225	35	■		■		NU 1030
160	240	38	■		■		NU 1032
170	260	42	■		■		NU 1034
180	280	46	■		■		NU 1036
190	290	46	■		■		NU 1038
200	310	51	■		■		NU 1040
220	340	56	■		■		NU 1044

¹) Non-standard sizes can be offered on request

²) The dimensions listed are indicative only, contact SKF for detailed product specification.

Cylindrical roller bearings for traction motors

Standard product range for medium loads¹

d 50 – 220 mm

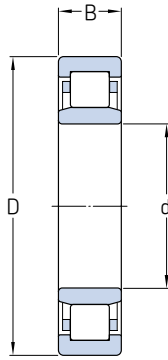

Principal dimensions ²			Preferred executions			Basic designation	
d	D	B	Standard bearing design	INSOCOAT outer ring coated VL0241	INSOCOAT inner ring coated VL2071		Hybrid design HC5
mm			–			–	
50	90	20	■	■		■	NU 210 EC
55	100	21	■	■		■	NU 211 EC
60	110	22	■	■		■	NU 212 EC
65	120	23	■	■		■	NU 213 EC
70	125	24	■	■		■	NU 214 EC
75	130	25	■	■		■	NU 215 EC
80	140	26	■	■		■	NU 216 EC
85	150	28	■	■			NU 217 EC
90	160	30	■	■			NU 218 EC
95	170	32	■	■			NU 219 EC
100	180	34	■	■			NU 220 EC
110	200	38	■	■			NU 222 EC
120	215	40	■	■			NU 224 EC
130	230	40	■		■		NU 226 EC
140	250	42	■		■		NU 228 EC
150	270	45	■		■		NU 230 EC
160	290	48	■		■		NU 232 EC
170	310	52	■		■		NU 234 EC
180	320	52	■		■		NU 236 EC
190	340	55	■		■		NU 238 EC
200	360	58	■		■		NU 240 EC
220	400	65	■		■		NU 244 EC

¹⁾ Non-standard sizes can be offered on request

²⁾ The dimensions listed are indicative only, contact SKF for detailed product specification.

Cylindrical roller bearings for traction motors

Standard product range for heavy loads¹

d 50 – 220 mm

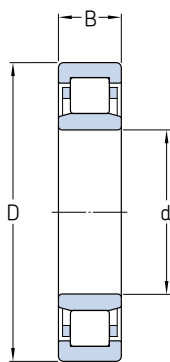

Principal dimensions ²			Preferred executions			Basic designation	
d	D	B	Standard bearing design	INSOCOAT outer ring coated VL0241	INSOCOAT inner ring coated VL2071		Hybrid design HC5
mm			–			–	
50	110	27	■	■		■	NU 310 EC
55	120	29	■	■		■	NU 311 EC
60	130	31	■	■		■	NU 312 EC
65	140	33	■	■		■	NU 313 EC
70	150	35	■	■		■	NU 314 EC
75	160	37	■	■			NU 315 EC
80	170	39	■	■			NU 316 EC
85	180	41	■	■			NU 317 EC
90	190	43	■	■			NU 318 EC
95	200	45	■	■			NU 319 EC
100	215	47	■	■			NU 320 EC
110	240	50	■	■			NU 322 EC
120	260	55	■		■		NU 324 EC
130	280	58	■		■		NU 326 EC
140	300	62	■		■		NU 328 EC
150	320	65	■		■		NU 330 EC
160	340	68	■		■		NU 332 EC
170	360	72	■		■		NU 334 EC
180	380	75	■		■		NU 336 EC
190	400	78	■		■		NU 338 EC
200	420	80	■		■		NU 340 EC
220	460	88	■		■		NU 344 EC

¹⁾ Non-standard sizes can be offered on request

²⁾ The dimensions listed are indicative only, contact SKF for detailed product specification.

Deep groove ball bearings for traction motors

Standard product range for light loads¹

d 50 – 220 mm

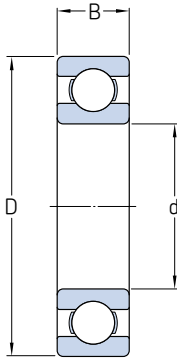

Principal dimensions ²			Preferred executions			Basic designation	
d	D	B	Standard bearing design	INSOCOAT outer ring coated VL0241	INSOCOAT inner ring coated VL2071		Hybrid design HC5
mm			–			–	
50	90	20	■	■		■	6210
55	100	21	■	■		■	6211
60	110	22	■	■		■	6212
65	120	23	■	■		■	6213
70	125	24	■	■		■	6214
75	130	25	■	■		■	6215
80	140	26	■	■		■	6216
85	150	28	■	■			6217
90	160	30	■	■			6218
95	170	32	■	■			6219
100	180	34	■	■			6220
110	200	38	■	■			6222
120	215	40	■	■			6224
130	230	40	■		■		6226
140	250	42	■		■		6228
150	270	45	■		■		6230
160	290	48	■		■		6232
170	310	52	■		■		6234
180	320	52	■		■		6236
190	340	55	■		■		6238
200	360	58	■		■		6240
220	400	65	■		■		6244

¹⁾ Non-standard sizes can be offered on request

²⁾ The dimensions listed are indicative only, contact SKF for detailed product specification.

Deep groove ball bearings for traction motors

Standard product range for medium loads¹

d 50 – 220 mm

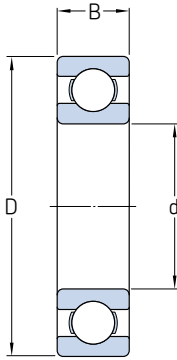

Principal dimensions ²			Preferred executions			Basic designation	
d	D	B	Standard bearing design	INSOCOAT outer ring coated VL0241	INSOCOAT inner ring coated VL2071		Hybrid design HC5
mm			–			–	
50	110	27	■	■		■	6310
55	120	29	■	■		■	6311
60	130	31	■	■		■	6312
65	140	33	■	■		■	6313
70	150	35	■	■		■	6314
75	160	37	■	■			6315
80	170	39	■	■			6316
85	180	41	■	■			6317
90	190	43	■	■			6318
95	200	45	■	■			6319
100	215	47	■	■			6320
110	240	50	■	■			6322
120	260	55	■		■		6324
130	280	58	■		■		6326
140	300	62	■		■		6328
150	320	65	■		■		6330
160	340	68	■		■		6332
170	360	72	■		■		6334
180	380	75	■		■		6336
190	400	78	■		■		6338
220	460	88	■		■		6344

¹) Non-standard sizes can be offered on request

²) The dimensions listed are indicative only, contact SKF for detailed product specification.

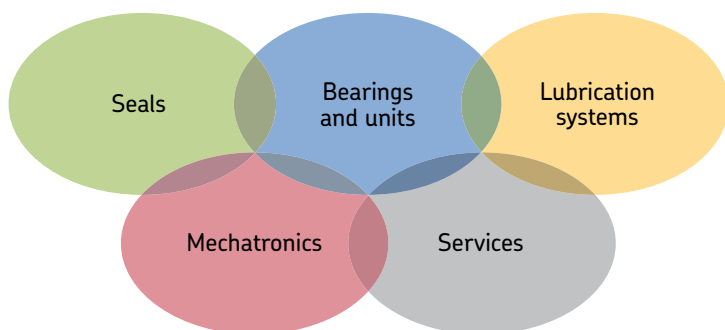

The Power of Knowledge Engineering

Drawing on five areas of competence and application-specific expertise amassed over more than 100 years, SKF brings innovative solutions to OEMs and production facilities in every major industry worldwide. These five competence areas include bearings and units; seals, lubrication systems, mechatronics (combining mechanics and electronics into intelligent systems), and a wide range of services, from 3-D computer modelling to advanced condition monitoring and reliability and asset management services. A global presence provides SKF customers uniform quality standards and universal product availability.

© SKF and INSOCCOAT are registered trademarks of the SKF Group.
All other trademarks are the property of their owner.

© SKF Group 2008

The contents of this publication are the copyright of the publisher and may not be reproduced (even extracts) unless permission is granted. Every care has been taken to ensure the accuracy of the information contained in this publication but no liability can be accepted for any loss or damage whether direct, indirect or consequential arising out of the use of the information contained herein.

Publication **6815 EN**

Printed in Austria on environmentally friendly paper.